

# QuietAir QT120

Toilet, bathroom, utility room and kitchen (adjacent to hob)



## KEY FEATURES

- Axial fan
- Two speed ventilation up to 170 m<sup>3</sup>/h
- Awarded Quiet Mark by Noise Abatement Society
- Quiet, noise level as low as 32 dB(A)
- Power consumption from only 10 W
- Very low SFP of 0.24 W/l/s, IP45 rating
- Interval timer for routine auto extraction
- Long-life ball bearings with approx. 40,000 hours life
- Integral flow straightener / backdraught flap
- Powerful extraction for longer ducts
- Suitable for installation anywhere in Zone 1 of Wbathrooms when installed with an RCD
- Install in a kitchen adjacent to the hob
- Complies with Building Regulations
- 3 year warranty

## QT120 Range

The powerful performance QuietAir 120 is designed to provide extraction levels that exceed the requirements of the latest Building Regulations.

QuietAir, is a range of elegant, discreet axial fans that are supremely quiet. By using exceptionally low energy they help to reduce carbon emissions but also save on your electricity bill.

Operated by a range of control options including basic switching, timer, humidity and motion sensor control.

Room refresh (interval timer) enables automatic extraction at pre-set times if required.



## MODELS

<b>Basic</b>	Control by remote switch
<b>Timer</b>	Adjustable timer overrun of 6,10,15 or 21 minutes
<b>Humidity Timer</b>	Adjustable Humidity 60 to 90% RH with adjustable timer
<b>Motion Sensor Timer</b>	Motion sensor activation



## TECHNICAL DATA

Specification	QuietAir QT120B	QuietAir QT120T	QuietAir QT120HT	QuietAir QT120MST
Air flow m <sup>3</sup> /h	150 / 170	150 / 170	150 / 170	150 / 170
Air flow l/s	42 / 47	42 / 47	42 / 47	42 / 47
Fan type	Axial	Axial	Axial	Axial
Controls	Basic	Timer	Humidity Timer	Motion Sensor Timer
Mounting	Wall / Ceiling	Wall / Ceiling	Wall / Ceiling	Wall / Ceiling
Sound pressure dB(A)@3 m	32/36	32/36	32/36	32/36
Delay start (min)	No	2	2	No
Adjustable timer (min)	No	6,10,15,21	6,10,15,21	15
Adjustable humidity (%RH)	-	-	60 - 90	-
Interval timer, auto start (hrs)	-	0,8,12,24	-	-
Power watts	10/13	10/13	10/13	10/13
Amps	0.08/0.09	0.08/0.09	0.08/0.09	0.08/0.09
Specific Fan Power (SFP)	0.24	0.24	0.24	0.24
Building Regulations ADF	Yes	Yes	Yes	Yes
Duct Diameter (mm)	125	125	125	125
Voltage	230 V / 1 ph / 50 Hz	230 V / 1 ph / 50 Hz	230 V / 1 ph / 50 Hz	230 V / 1 ph / 50 Hz
Rating	IP45	IP45	IP45	IP45
Max ambient temperature	40°C	40°C	40°C	40°C
Weight (kg)	1.05	1.05	1.05	1.05
Dimensions (H x W x D) mm	176 x 176 x 155	176 x 176 x 155	176 x 176 x 155	176 x 176 x 155
Part No.	<b>9041497</b>	<b>9041498</b>	<b>9041499</b>	<b>9041500</b>
EAN Barcode	<b>5019009307589</b>	<b>5019009307596</b>	<b>5019009307602</b>	<b>5019009307619</b>

## DIMENSIONS (mm)

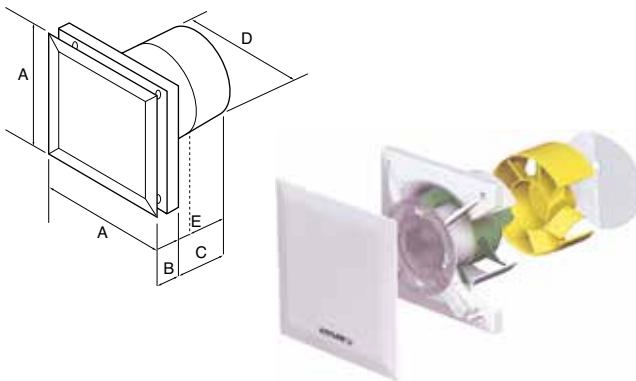

Model	A	B	C	D	E
QuietAir QT120	176	39	116	118	70

## PERFORMANCE

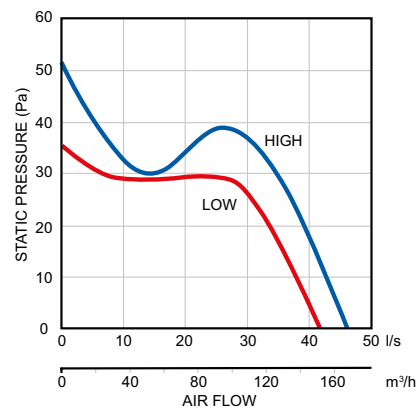

## CONTROLS AND ACCESSORIES

A range of accessories including flexible and rigid ducting kits, controls, switches and grilles are available.

See accessories section for more details.

Call: 01494 525252

Visit: [airflow.com](http://airflow.com)



**Airflow Developments Limited**  
Aidelle House, Lancaster Road,  
Cressex Business Park,  
High Wycombe, Buckinghamshire,  
United Kingdom, HP12 3QP

E-mail: [info@airflow.com](mailto:info@airflow.com)  
Telephone: +44 (0) 1494 525252

[airflow.com](http://airflow.com)

© Airflow Developments Limited. Airflow Developments Limited reserve the right, in the interests of continuous development, to alter specifications without prior notice. All orders are accepted subject to our conditions of sale which are available on request



80001415 - Issue 3 03/24